

Brain Region and Isoform-Specific Phosphorylation Alters Kalirin SH2 Domain Interaction Sites and Calpain Sensitivity

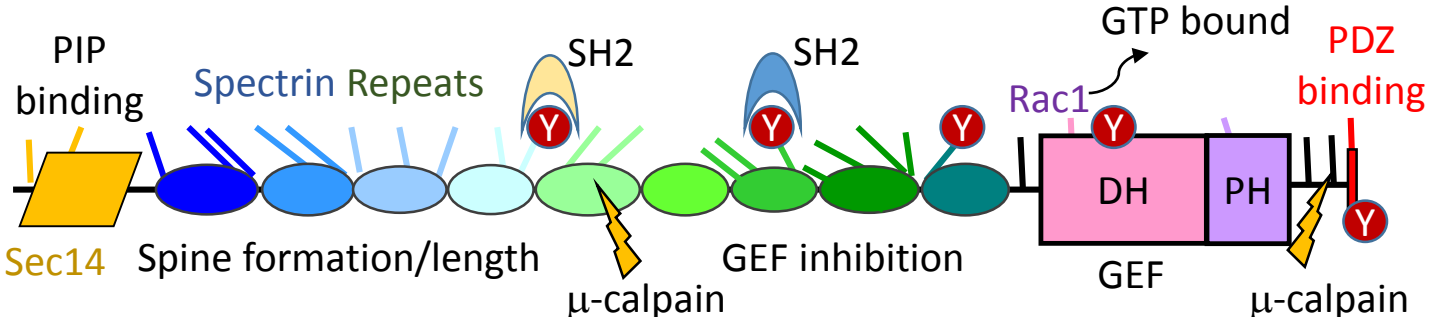

Betty Eipper

University of Connecticut Health Center

Yale/NIDA Neuroproteomics Center External
Advisory Board Meeting
5/1/19

Kalirin (*Kalrn*):

Secretory Granule interactor
&
GDP/GTP Exchange Factor
(GEF) for Rac1:
actin → spines

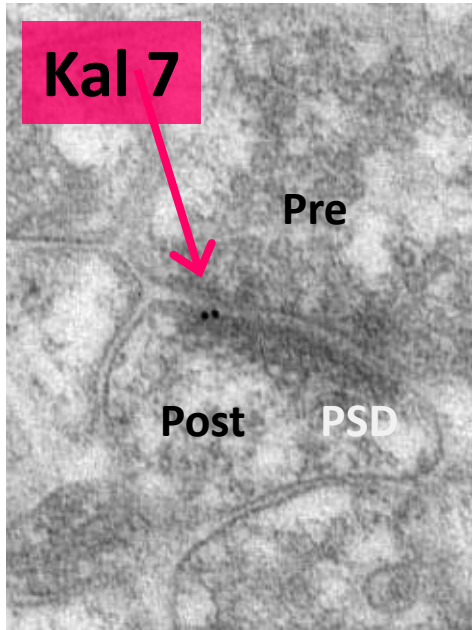

Richard Weinberg, UNC

Major *Kalrn* Isoforms

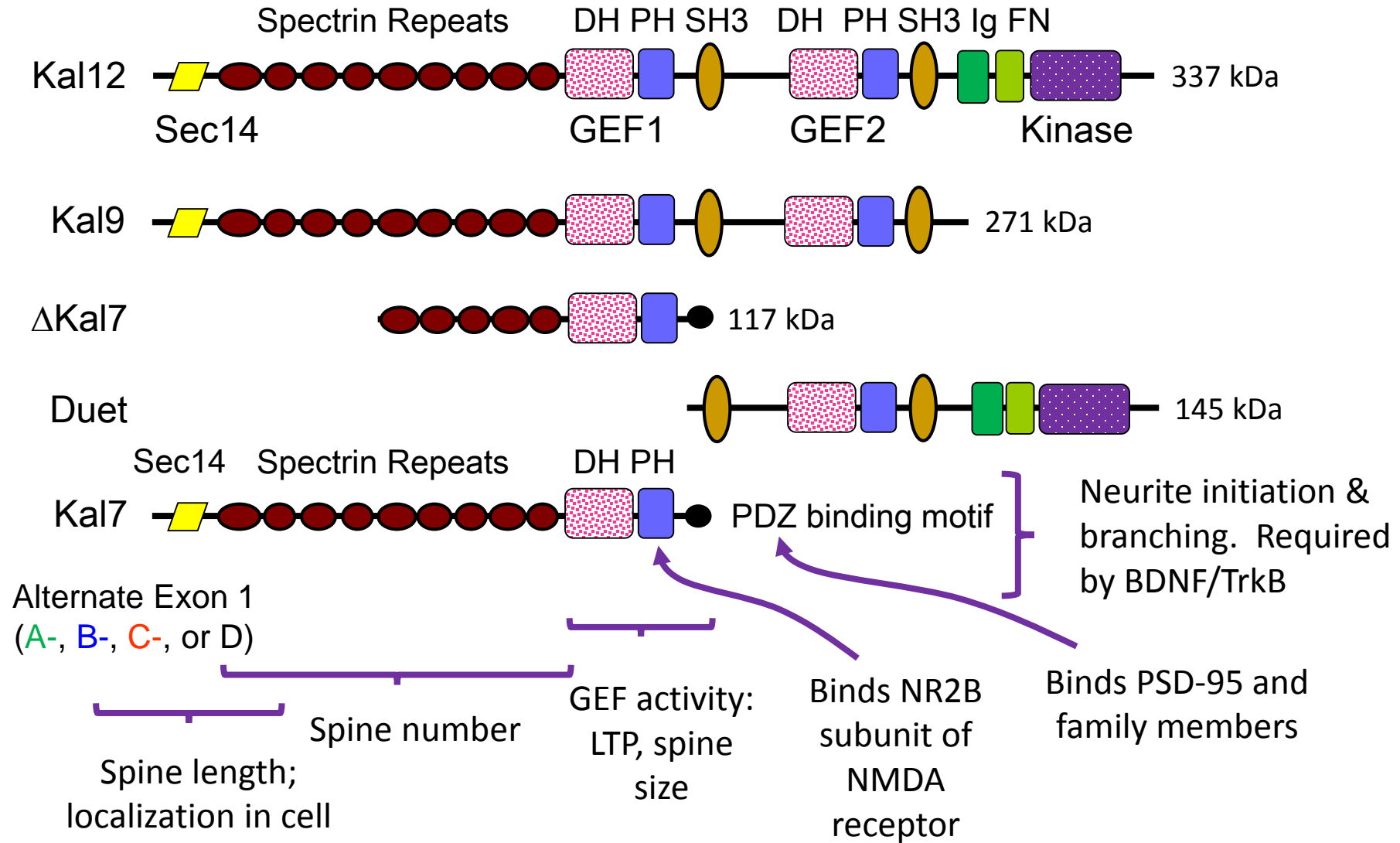

Genetics: *KALRN* implicated in schizophrenia, stroke, autism, substance abuse and intellectual disability

Kal7^{KO} and wildtype mice respond differently to cocaine

Kal7^{KO} mice

↓ spine density in hippocampus

↓ NR2B-dependent LTP

Deficits in fear based learning

↓ Anxiety-like behavior

Baseline – no change in spine density in nucleus accumbens

No ↑ in spine density in nucleus accumbens after cocaine

↑ Locomotor response to experimenter administered cocaine

↓ Cocaine place preference

Increased self-administration of cocaine at lower doses

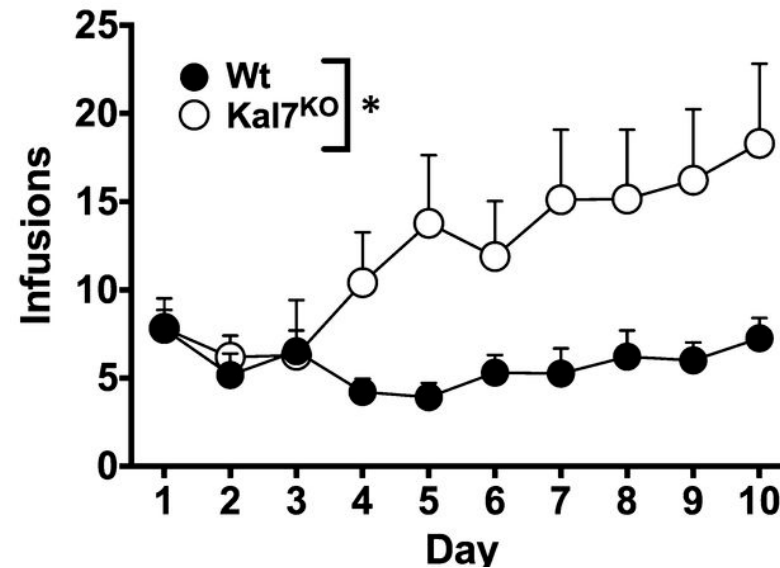

Cocaine self-administration:
0.5 mg/kg/infusion and saline.

Kiraly DD et al (2013) Mol Pharmacol 84, 582-590

Wanted to explore possibility that phosphorylation regulates *Kalrn* function

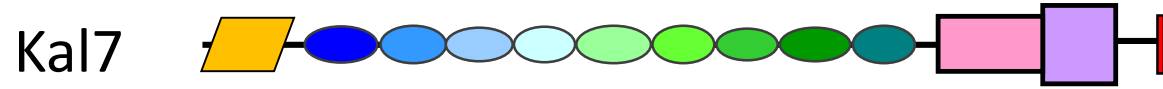

Genetic studies of axonal pathfinding in *Drosophila* suggested that Abl phosphorylated Kalirin/Trio family proteins [Liebl EC et al (2000) Neuron 26, 107-118]

Phosphorylation of Kal7 by CaMKII (downstream of NMDAR), Cdk5 (affects protrusions), PKA, PKC, CKII, Fyn, TrkB (in SR9), serum-inducible, glucocorticoid inducible kinase 1 SGK1 (mediates neuropathic pain in spinal cord), MAPKAPK5 (in SH3 binding motif of SR3)

Mouse brain Kal7 & HEK cell myc-Kal7: multiply phosphorylated - sites differ

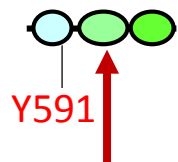

Phosphorylation of Kal SR4:6 by Abl1 makes it **more sensitive to cleavage by calpain** – Ca²⁺ activated protease essential for LTP

Abl inhibitors (e.g. GNF-5) **INCREASE** spine formation in cultured neurons

More spines; not longer spines

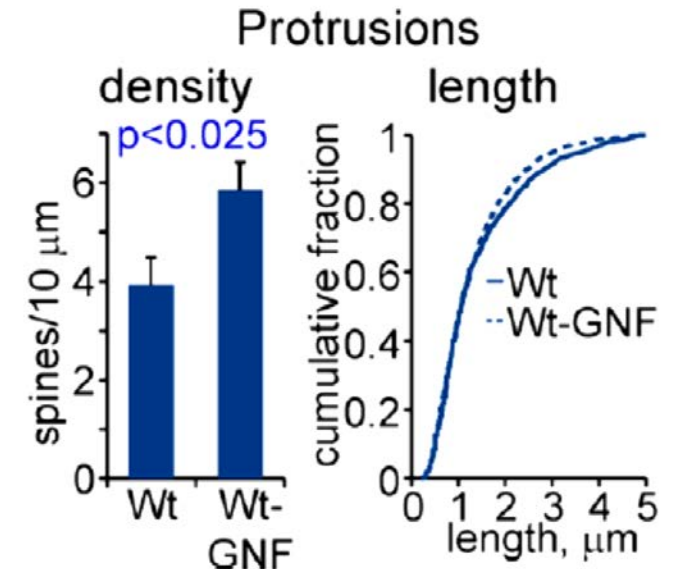
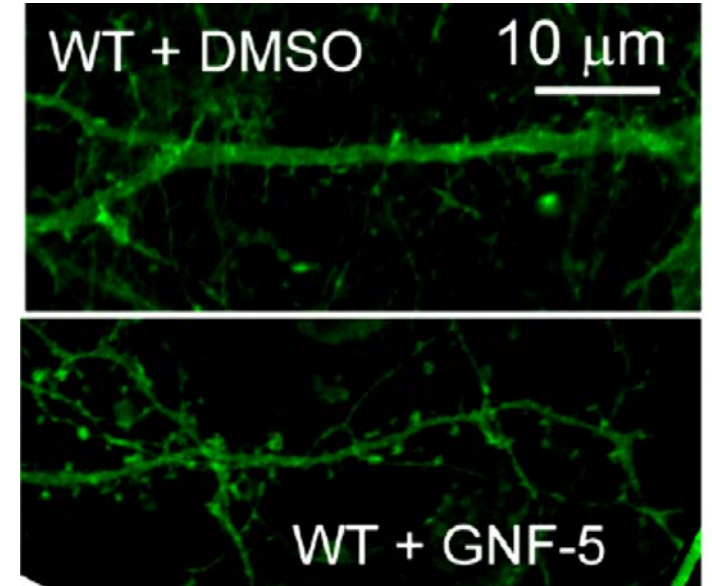

Phosphorylation: Isoform Specificity, Tissue Specificity, Regulation

20 Adult male rats - 7 daily injections of Saline (S), Acute (A) or Chronic (C) Cocaine (20 mg/kg)

Make coronal sections

Extract bilateral punches of Nucleus Accumbens (NAc) & Prefrontal Cortex (PFC)

Immunoprecipitate Kalirin from samples containing 2 mg protein

SDS PAGE followed by silver stain

Excise Kal7 and Kal9/Kal12 for in-gel trypsin digestion and analysis

Compare NAc to PFC (Saline)

Compare K7 to Kal9/Kal12 (Saline)

Compare Cocaine (Acute and Chronic) to Saline

80 samples!!!!

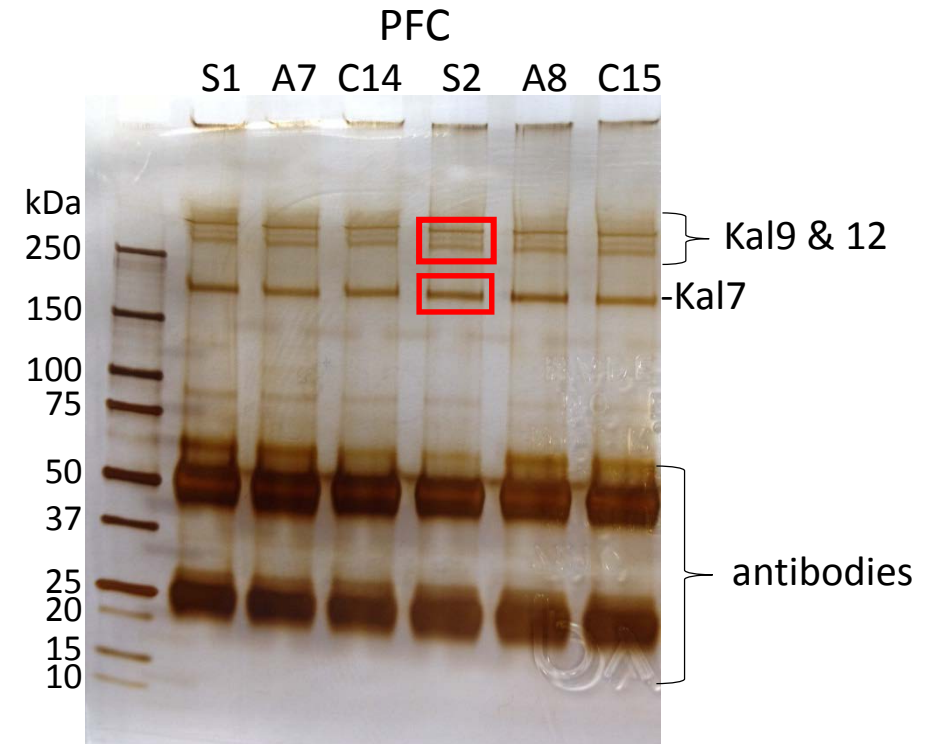
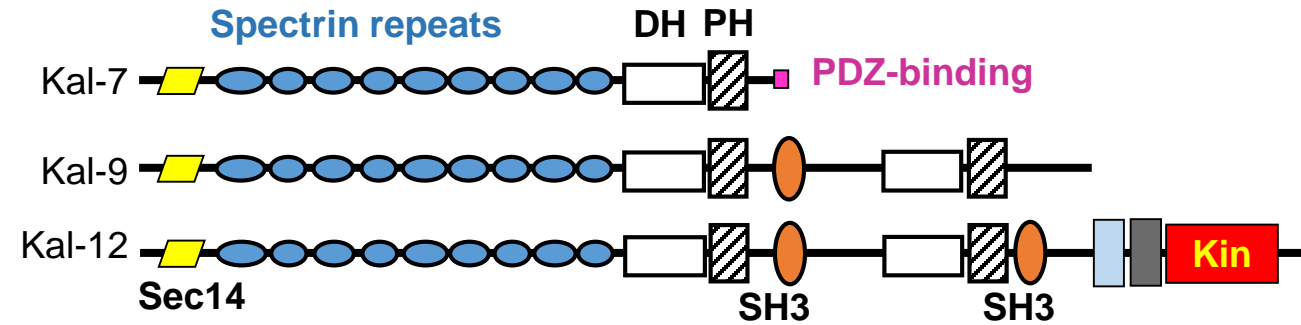

Miller MB et al (2017) ACS Chem Neurosci. Jul 19;8(7):1554-1569

Tissue-specific phosphorylation of Kal7: 26 phosphorylation sites – 5 pTyr (pY)

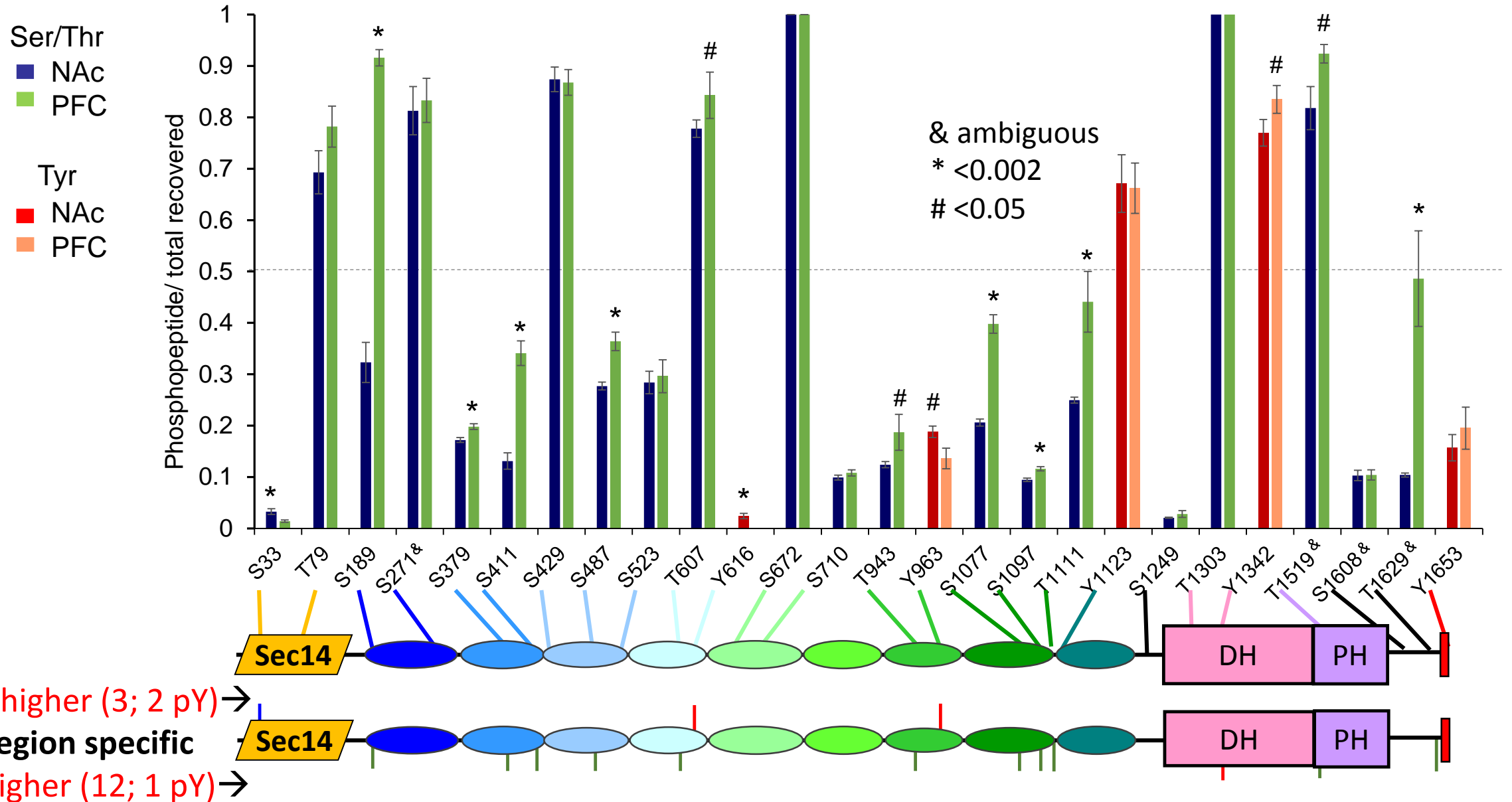

Phosphorylation is isoform specific

Phosphorylation sites identified in Kal9/Kal12

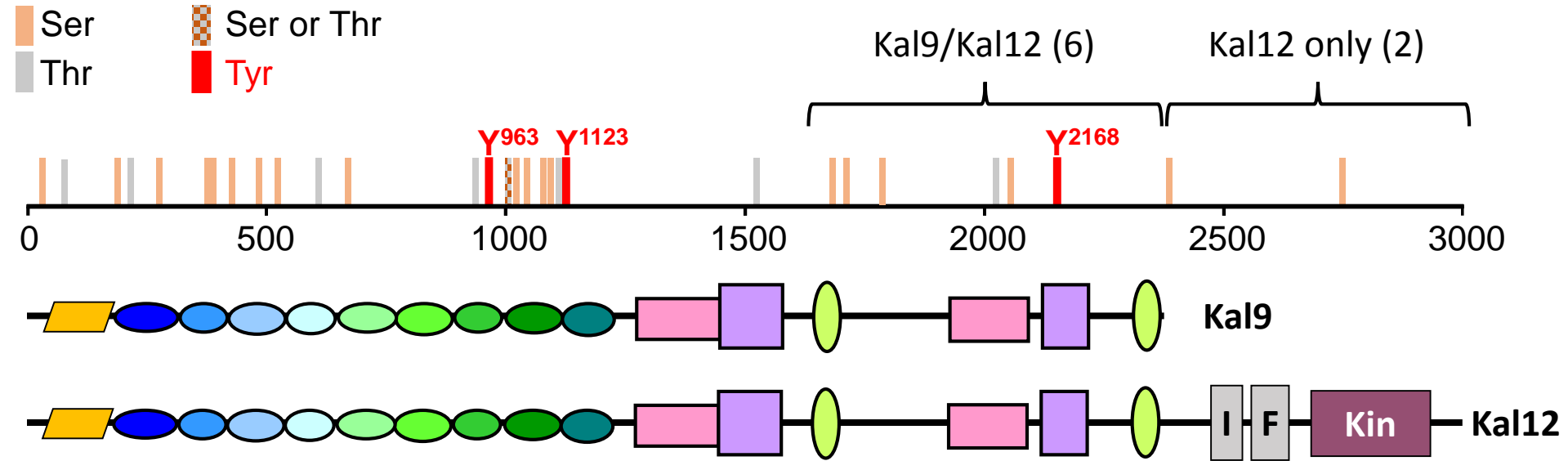

Differences between Kal7 and Kal9/12 Phosphorylation

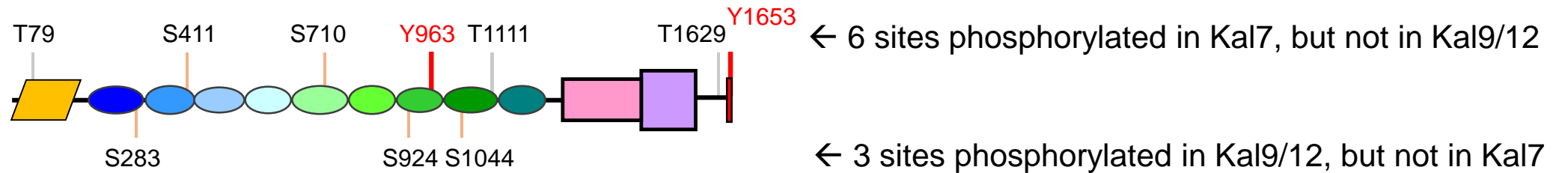

Sec14: single phosphorylation site
 – heavily phosphorylated in Kal7;
 not phosphorylated in Kal9/Kal12

Kal7 phosphorylation is altered in a tissue-specific manner in response to cocaine

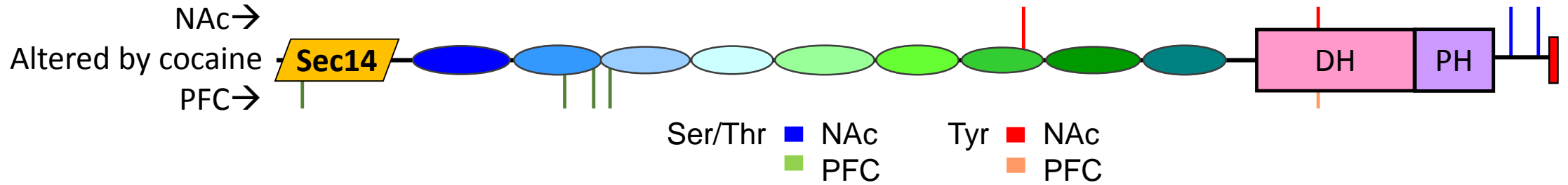

PFC:
Mostly
N-terminal

NAc:
C-terminal
2 of 4 pY

Site	Domain	Tissue	Effect of Cocaine Treatment (% P)		p value	
S33	Sec14	PFC	1 ± 0.5	saline < acute	3 ± 0.5	0.028
S379	SR2	PFC	18 ± 1	acute < saline	20 ± 1	0.006
S411	SR2	PFC	26 ± 2	acute < saline	33 ± 2	0.013
S429	SR3	PFC	72 ± 3	chronic < saline	88 ± 3	0.024
Y963	SR7	NAc	12 ± 2	chronic < acute & saline	19 ± 1	0.003
Y1342	DH	NAc	70 ± 4	chronic < acute	83 ± 3	0.018
Y1342	DH	PFC	72 ± 3	chronic < saline	82 ± 2	0.040
S1608 ^{&}	linker	NAc	10 ± 1	saline < acute	14 ± 1	0.024
T1629 ^{&}	linker	NAc	8 ± 1	chronic < acute	12 ± 2	0.004

To follow up on prevalence of pY (P-Tyr): look for SH2 domains that bind pY-peptides

Kazuya Machida (UCHC): SH2 domains

120 human SH2 domains

SH2 domains stay bound for ~ 100 msec

Tyr kinase and phosphatase activities are high

pY lifetimes are ~ 15 sec

Sequences	
Y616:	P EEI (p) Y KAARHLE
Y963:	QAGH(p) Y DADAIRE
Y1123:	QCQQ(p) Y VVFERSA
Y1342:	E LEK(p) Y EQLPDEV

Screening	
SH2 domains (62 genes)	72
PTB domains	1
PTP domains	2
GST control	1
Total probes used	76

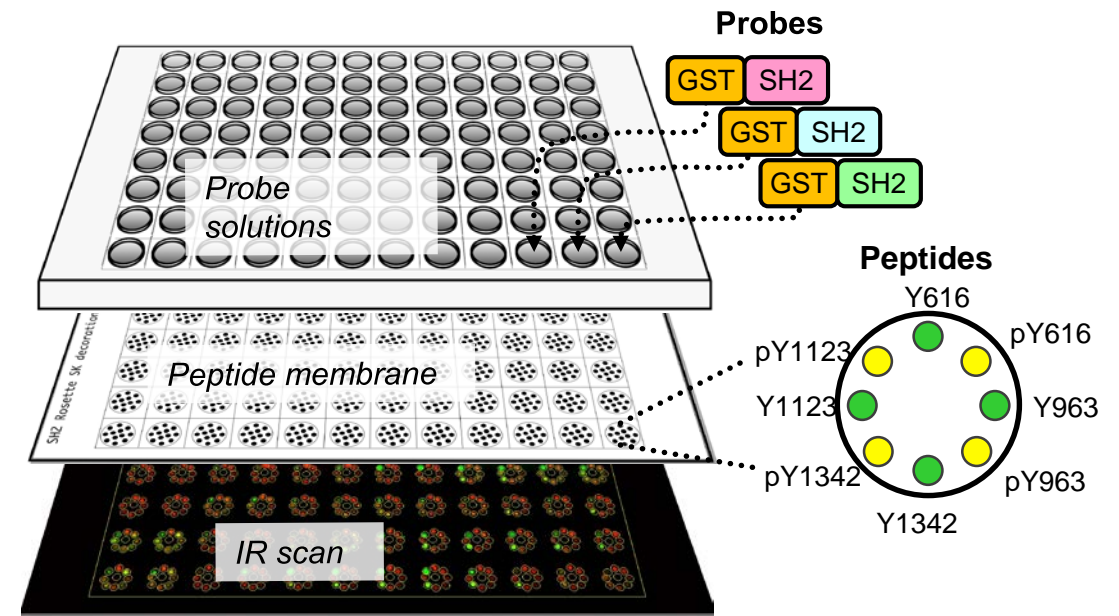

Express GST-SH2 fusions; worked with 76 probes

Test for binding to biotinylated pY and control peptides spotted into 96-well plates

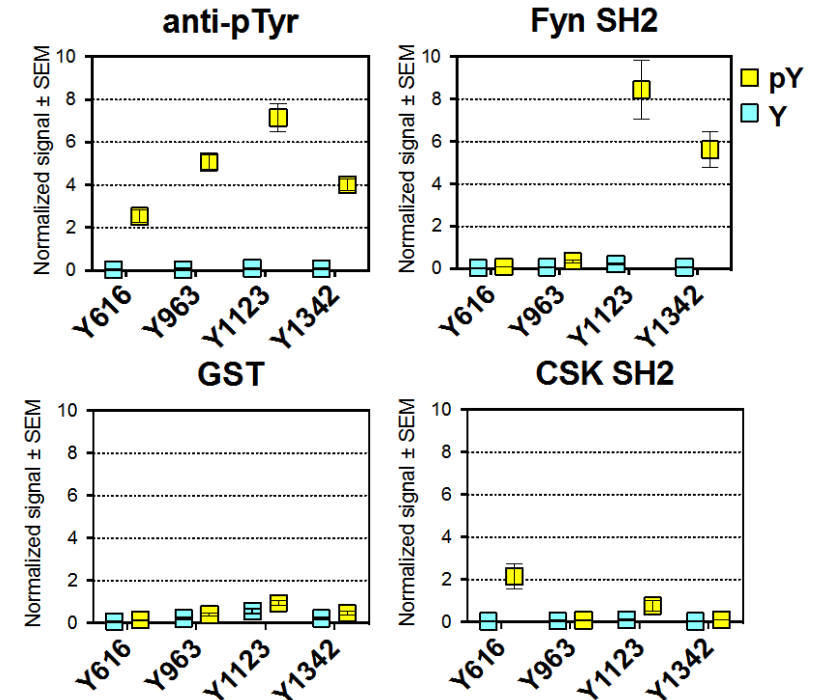
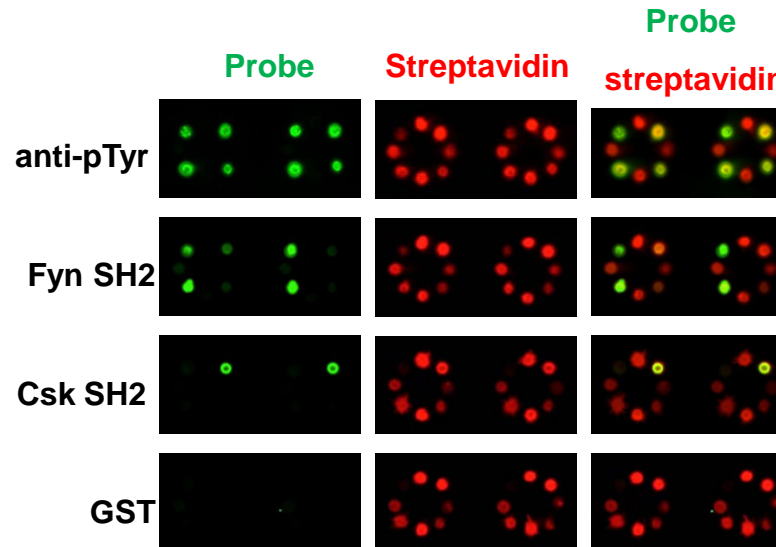

Does phosphorylation of Kalirin alter its GEF activity or its stability?

There are ~ 85 GEFs in the human genome, over half are expressed in brain

Kalirin/Trio are the only family members with two GEF domains – GEF1 for Rac1 and GEF2 for RhoA

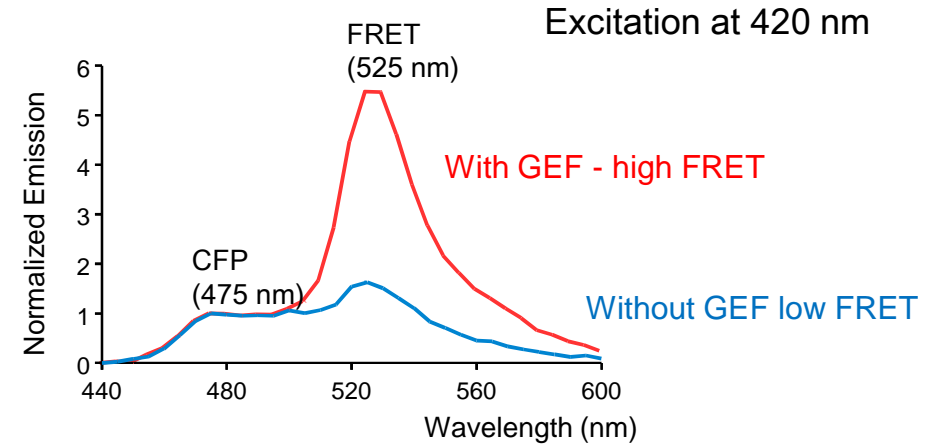

Rac1 biosensor

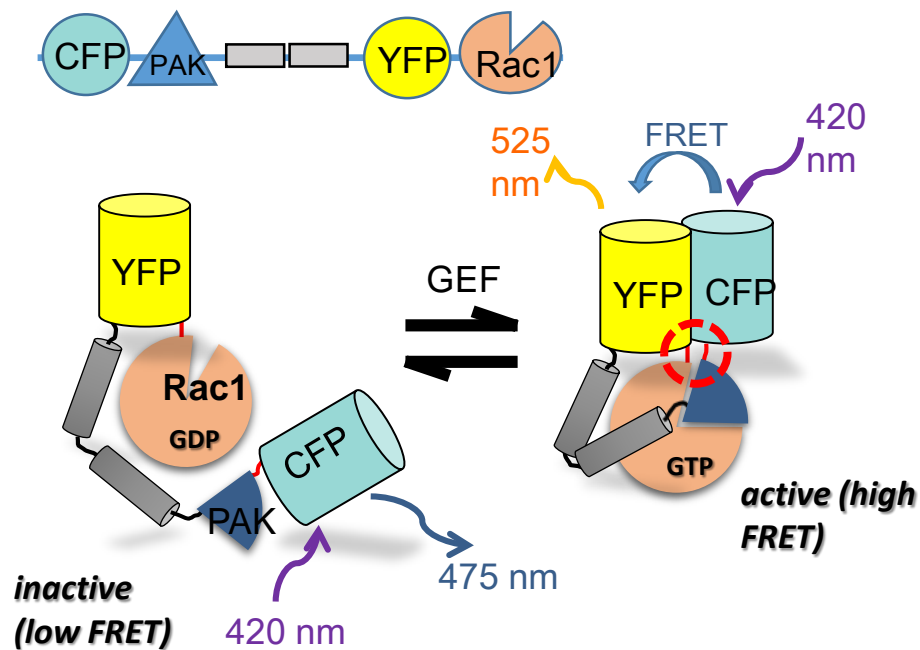

DH/PH domain:

4 sites, each heavily phosphorylated

Replace 3 or 4 with non-phosphorylatable residue:
No effect on activity – phosphorylation not required for activity

Kal7

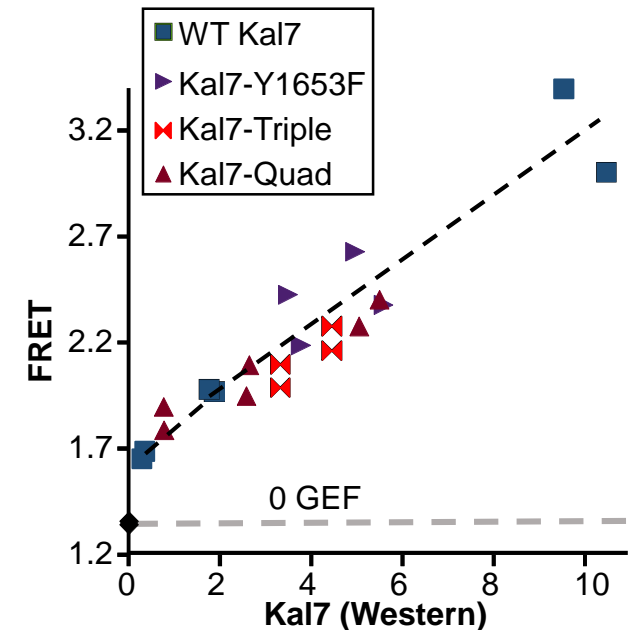

What happens when a negatively charged amino acid is placed at a phosphorylation site?

Screened 9 sites:

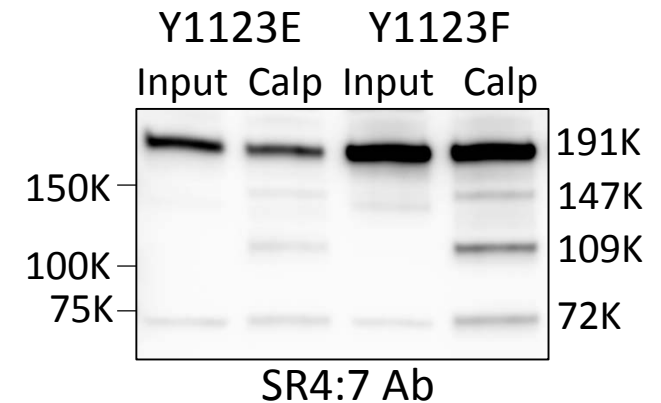
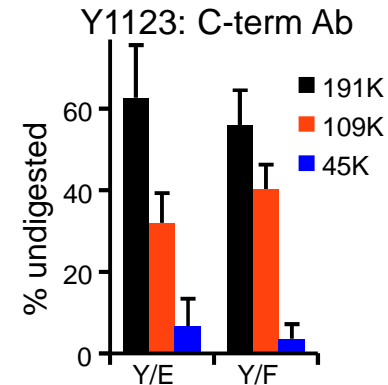
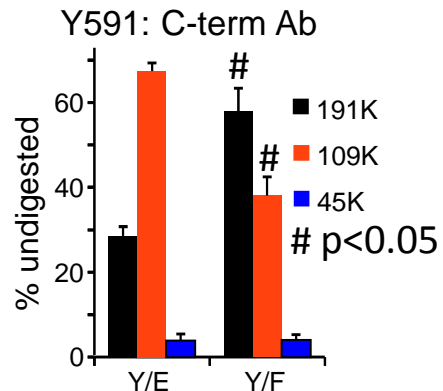
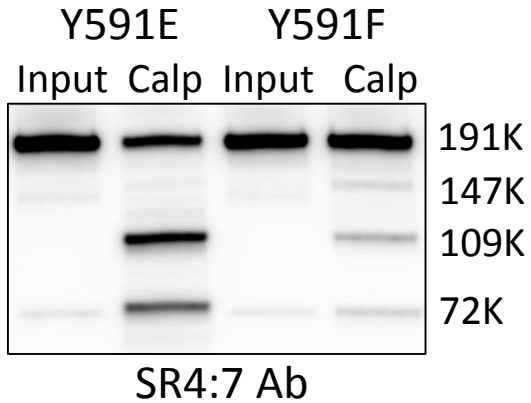
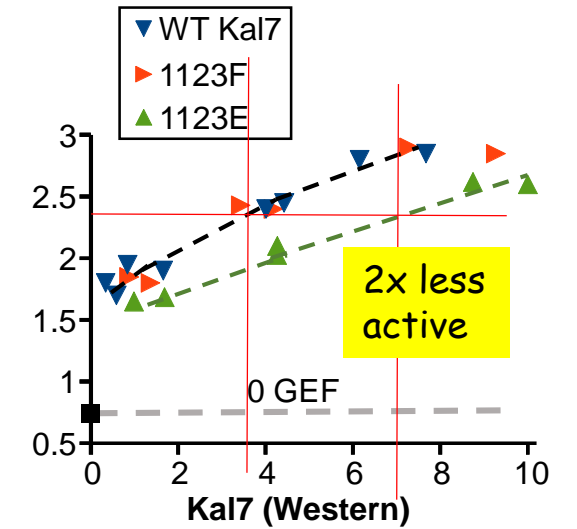
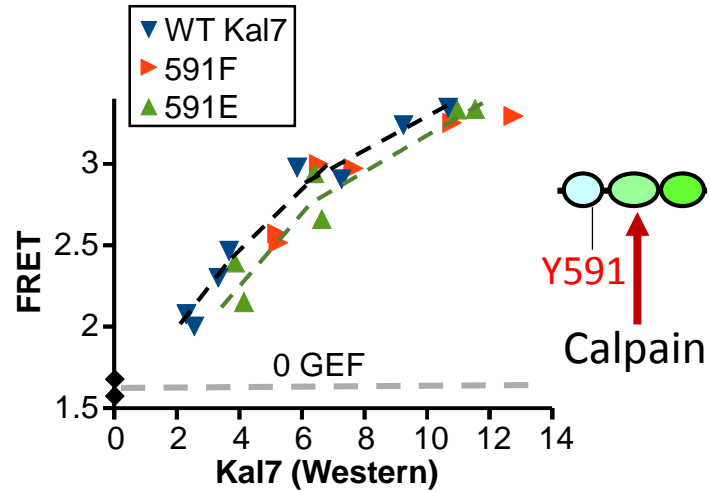
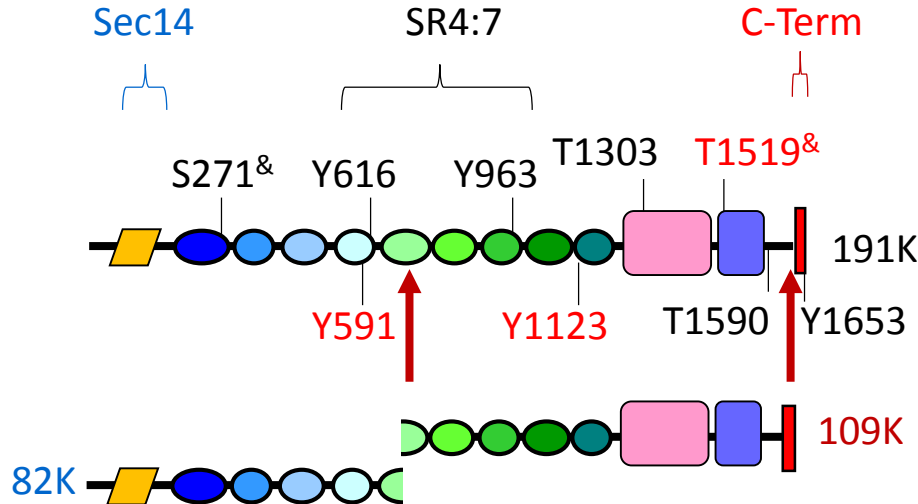



Yale/NIDA Neuroproteomics Center

Jean Kanyo
TuKiet Lam
Navin Rauniyar
Thomas Abbott
Rashaun Wilson
Ken Williams

UCHC:

Dick Mains
Drew Kiraly
Megan Miller
Vishwanatha Rao
Eric Gaier
Xin-Ming Ma
Yan Yan
Kazuya Machida
Fouad Lemtiri-Chlieh
Mason Yeh
Eric Levine
Bing Hao
Yi Wu

Collaborators:

Anthony Koleske
Aaron Levy
Foster Olive

Funding:

NIDA
NIDDK
Janice and Rodney Reynolds
Endowment
Schwartzberg Fund
Stanley Center for
Psychiatric Research